

LUMICHRON BRACKET CLOCKS

Lumichron bracket clocks feature a wall or ceiling mounted double-faced clock with internal LED illumination and fully automatic, hands-free time controls. Standard sizes in 6" increments 18" to 42" in Modern styles of a fixed size 30" diameter Victorian with a header panel.

▲ BENEFITS OF BRACKET CLOCKS

Commonly used where space on a sidewalk is not usable, these clocks mount above a store-front and project out as a useful 'attraction' or are used in a common area indoors and suspend from a ceiling such as a station lobby. Any transit facility can use a good, accurate bracket clock!

▲ INSTALLATION

All bracket clocks are either mounted on a wall or ceiling so provisions for such installation need to be taken into account. Each clock is made-to-order, so if mounting on a column, hollow wall, or ceiling, the clock will be designed for the correct application. All require a remote master clock with a low-voltage wired connection.

▲ STANDARD FEATURES

- All-aluminum cabinet construction, powder coated in stock architectural finishes
- Tempered glass crystals for haze-free lifespan
- Fully automatic time controls with optional GPS synchronization
- Internal illumination with 100,000 hr sign-grade LED's
- Customizable dial designs with header panel options if needed
- Modern styles in 6" increments from 18" to 42" (30" is most popular)
- A standard Victorian bracket clock with a 30" OD head with header panel, projects 48" overall and is 48" overall height
- Options for building into a custom sign, mounting on a corner, etc.

▲ CONSIDERATIONS WHEN ORDERING

- Height from grade
- Wiring connections (a wire has to feed through the wall/ceiling)
- Wall/ceiling construction for anchors/bolts, etc.
- If power is not available, self-setting GPS synchronized industrial movements powered by 5 year DD lithium batteries are available



CRAFTSMANSHIP

Every clock is built-to-order, by people passionate about the craft of building time for clients. Always personal, always on-time, and always on-budget.

TRADITION

From old world Roman style to contemporary modern, an analog clock is a notable feature bringing importance and comfort to the building

TECHNOLOGY

All clocks are digitally controlled, synchronized with GPS or NTP for accuracy

FOR PRICING, CSI SPECIFICATIONS, ETC., PLEASE CALL OR EMAIL
11460 Dorsett Rd., Maryland Heights, MO 63043

Tel: 616-245-8888
Email: sales@lumichron.com
lumichron.com

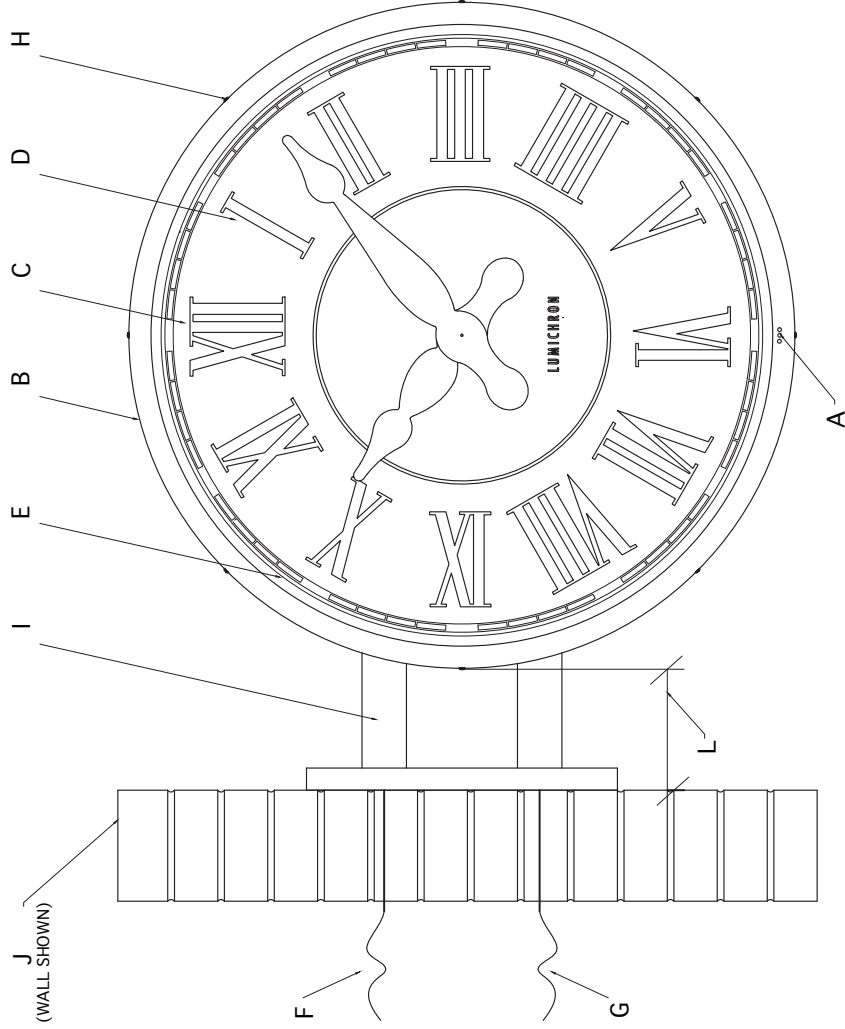
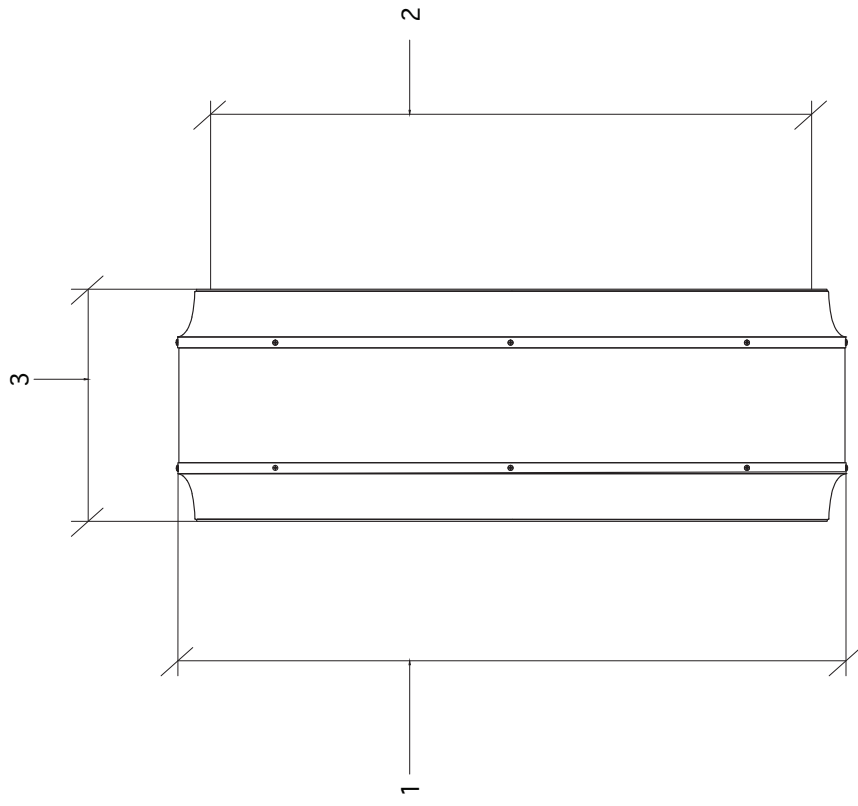

DIMENSIONS		24" CLOCK	30" CLOCK	36" CLOCK	42" CLOCK
BB	1 CASE DIAMETER	24"	30"	36"	42"
	2 FACE OPENING	21 1/2"	27"	33"	39"
	3 CASE WIDTH	11"	11"	11"	11"
SPECIFICATION KEY					
AA	MODEL NUMBER	MO. NUMBER - SIZE - PROJECTION - DIAL/HAND-COLOR (SHOWN): BR-30-6-STD. ROMAN/ROMAN SPADE*-BLACK			
BB	SIZE	SEE CONFIGURATIONS (BR SHOWN)			
CC	PROJECTION DISTANCE	SEE CONFIGURATIONS (30" SHOWN)			
DD	DIAL/HAND	SEE SEPARATE SELECTION PAGE*			
EE	COLOR	BLACK (DEFAULT), BRONZE, SILVER, GREY, SPEC.			

TITLE: EXTERIOR DOUBLE FACED BRACKET CLOCK

SCALE: _____ DATE: _____ DRAWN: _____ CHECKED: _____

DRAWING NO: _____ REVISION: _____

LUMICHRON
COMMERCIAL CLOCKS
LUMICHRON.COM

11460 Dorsett Rd., Maryland Heights, MO, 63043
(616) 245-8888 SALES@LUMICHRON.COM

FEATURES	CONFIGURATIONS
A ALL-ALUMINUM CASE, SCREENED VENT AND DRAIN HOLES	
B ARCHITECTURAL GRADE POWDER COATING	
C BACK-LIT DIALS WITH 100,000 HR SIGN-GRADE LED'S	
D UNBREAKABLE SIGN-GRADE (UV PROTECTED) POLYCARBONATE DIALS	
E TEMPERED GLASS CRYSTALS PROTECTING THE DIALS AND HANDS	
F 24 POWER FOR IMPULSE DRIVE 24V SLAVE CLOCK MOVEMENTS (SEE WIRE DIAGRAM)	
G ILLUMINATION (SEE WIRE DIAGRAM)	
H STAINLESS STEEL FASTENERS THROUGHOUT	
I BR-BRACKET, SU-SUSPENDED, PD-PEDESTAL, DOUBLE-FACED, IN SIZES 24", 30", 36", OR 42" (OD)	AA
J WALL, CEILING, OR PEDESTAL	
K FULL CUSTOMIZATION AVAILABLE WITH HEADER/FOOTER PANELS, CORNER MOUNT, ETC	
L PROJECTION/DROP-DOWN/RISE TO BE SPECIFIED	CC